

FV25B/3 - ***PV (S)

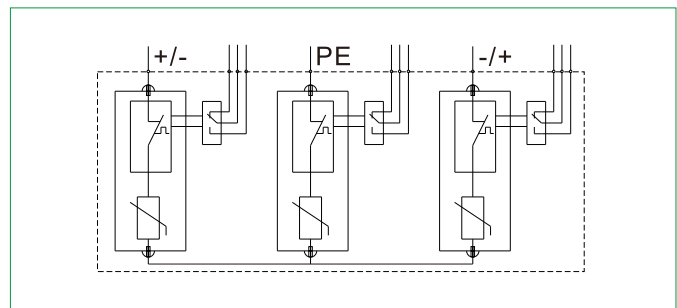

- ◆ DC surge protective device used for photovoltaic system.
- ◆ The core parts are metal oxide varistor components with high discharge capacity.
- ◆ With Reliable control thanks to Thermo Dynamic Control disconnecter.
- ◆ Remote signaling contact for control device optional.
- ◆ Fault indication via red mark in the inspection window.
- ◆ 3 poles, Y type.

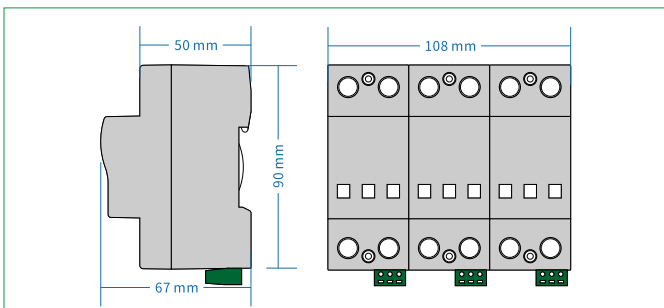

Model No.	FV25B/3-500PV (S)	FV25B/3-600PV (S)
Test class according IEC/EN 50539-11	Class I/B/II	
Type of network	Photovoltaic system	
Protection Mode	+/- — PE 、 -/+ — PE 、 +/- — -/+	
Nominal voltage 50(60)Hz U _N	500V dc	600V dc
Maximum continuous operating voltage for PV application U _{CPV}	560V dc	670V dc
Max. discharge current (8/20μs) I _{max}	100kA	
Nominal discharge current (8/20μs) I _n	50kA	
Impulse current (10/350μs) I _{imp}	25kA	
Voltage protection level U _p	≤2.8kV	≤3.4kV
Response time t _A	≤25ns	
Recommended back-up fuse	315A	
Isolation resistance	>10 ² MΩ	
I/O Connections	Multi core wire: 6mm ² ~35mm ²	
Mounting	35mm Symmetrical rail (EN50022/DIN46277-3)	
Operation temperature range / humidity / altitude	-40°C~+80°C / 30%~90% / 3000m	
Degree of protection	IP20	
Housing material	UL94 V-0	
Disconnection indicator	Mechanical indicator (Red: replace)	
Remote control contact	Optional	

Port definition of remote control contact	Range of signal access		Recommended wire specification	
	AC	U _{max} ≤250V	Single core wire	Max ≤1.5mm ²
		I _{max} ≤0.5A		
	DC	U _{max} ≤60V	Multi core wire	Max ≤1.3mm ²
		I _{max} ≤0.1A		

Remark: if the model number is without "S", the model is without remote control contact function