

## FV20C/3 - \*\*\*PV (S)

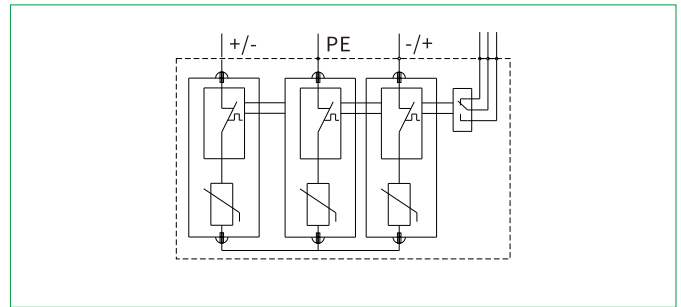

- ◆ DC surge protective device used for photovoltaic system.
- ◆ The core parts are metal oxide varistor components with high discharge capacity.
- ◆ With Reliable control thanks to Thermo Dynamic Control disconnecter.
- ◆ Remote signaling contact for control device optional.
- ◆ Fault indication via red mark in the inspection window.
- ◆ 3 poles, Y type.

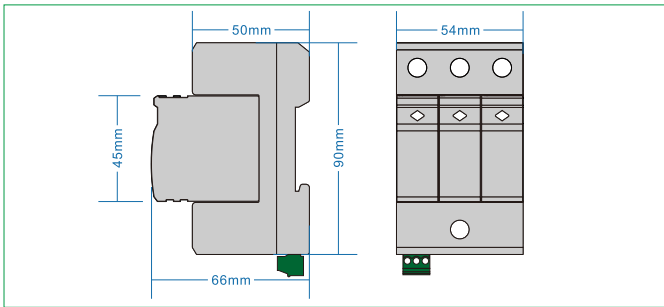

Model No.	FV20C/3-48PV (S)	FV20C/3-96PV (S)	FV20C/3-500PV (S)	FV20C/3-600PV (S)	FV20C/3-800PV (S)	FV20C/3-1000PV (S)	FV20C/3-1500PV (S)
Test class IEC/EN/VDE	Class II/C/ <u>T2</u>						
Type of Network	Photovoltaic system						
Protection Mode	+/- — PE 、 -/+ — PE 、 +/- — -/+						
Nominal voltage 50(60)Hz U <sub>N</sub>	48V dc	96V dc	500V dc	600V dc	800V dc	1000V dc	1500V dc
Rated Voltage (Max. Cont. Operating Voltage) U <sub>CPV</sub>	75V dc	125V dc	560V dc	670V dc	825V dc	1060V dc	1800V dc
Max. discharge current (8/20μs) I <sub>max</sub>	40kA						
Nominal discharge current (8/20μs) I <sub>n</sub>	20kA						
Voltage protective level U <sub>p</sub>	≤0.6kV	≤0.8kV	≤1.8kV	≤2.4kV	≤3.0kV	≤3.6kV	≤5.0kV
Response time t <sub>a</sub>	≤25ns						
Recommended back-up fuse	125A						
Isolation resistance	>10 <sup>2</sup> MΩ						
I/O Connections	Multi core wire: 4mm <sup>2</sup> ~25mm <sup>2</sup>						
Mounting	35mm Symmetrical rail (EN50022/DIN46277-3)						
Operation temperature range / humidity / altitude	-40°C~+80°C / 30%~90% / 3000m						
Degree of protection	IP20						
Housing material	UL94 V-0						
Disconnection indicator	Mechanical indicator (Green: OK, Red: replace)						
Remote control contact	Optional						

Port definition of remote control contact	Range of signal access		Recommended wire specification	
	AC	U <sub>max</sub> ≤ 250V	Single core wire	Max ≤ 1.5mm <sup>2</sup>
		I <sub>max</sub> ≤ 0.5A		
	DC	U <sub>max</sub> ≤ 60V	Multi core wire	Max ≤ 1.3mm <sup>2</sup>
		I <sub>max</sub> ≤ 0.1A		

Remark: if the model number is without "S", the model is without remote control contact function