

## FV20C/2 - \*\*\*PV (S)

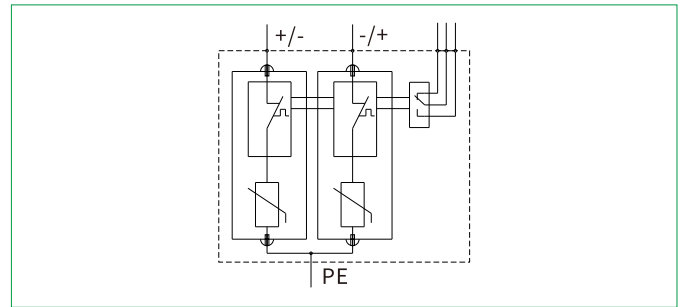

- ◆ DC surge protective device used for photovoltaic system.
- ◆ The core parts are metal oxide varistor components with high discharge capacity.
- ◆ With Reliable control thanks to Thermo Dynamic Control disconnecter.
- ◆ Remote signaling contact for control device optional.
- ◆ Fault indication via red mark in the inspection window.
- ◆ Type 2/ Class C.
- ◆ 2 poles, U type.

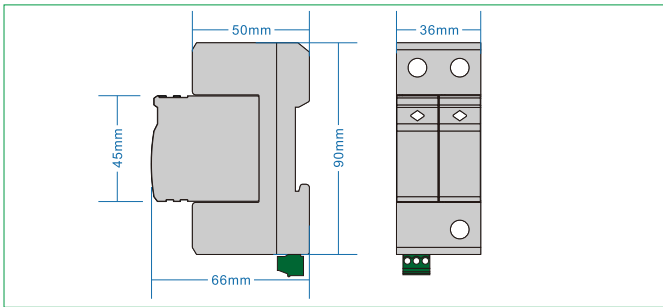

Model No.	FV20C/2-48PV (S)	FV20C/2-96PV (S)	FV20C/2-500PV (S)	FV20C/2-600PV (S)	FV20C/2-800PV (S)	FV20C/2-1000PV (S)
Test class IEC/EN/VDE	Class II/C/ <u>TT2</u>					
Type of Network	Photovoltaic system					
Protection Mode	+/- — PE 、 -/+ — PE					
Nominal voltage 50(60)Hz U <sub>N</sub>	48V dc	96V dc	500V dc	600V dc	800V dc	1000V dc
Rated Voltage (Max. Cont. Operating Voltage) U <sub>CPV</sub>	75V dc	125V dc	560V dc	670V dc	825V dc	1060V dc
Max. discharge current (8/20μs) I <sub>max</sub>	40kA					
Nominal discharge current (8/20μs) I <sub>n</sub>	20kA					
Voltage protective level U <sub>p</sub>	≤0.6kV	≤0.8kV	≤1.8kV	≤2.4kV	≤3.0kV	≤3.6kV
Response time t <sub>a</sub>	≤25ns					
Recommended back-up fuse	125A					
Isolation resistance	>10 <sup>2</sup> MΩ					
I/O Connections	Multi core wire : 4mm <sup>2</sup> ~25mm <sup>2</sup>					
Mounting	35mm Symmetrical rail (EN50022/DIN46277-3)					
Operation temperature range / humidity / altitude	-40°C~+80°C / 30%~90% / 3000m					
Degree of protection	IP20					
Housing material	UL94 V-0					
Disconnection indicator	Mechanical indicator (Green: OK, Red: replace)					
Remote control contact	Optional					

Port definition of remote control contact	Range of signal access		Recommended wire specification	
	AC	U <sub>max</sub> ≤250V	Single core wire	Max ≤1.3mm <sup>2</sup>
		I <sub>max</sub> ≤0.5A		
	DC	U <sub>max</sub> ≤60V	Multi core wire	Max ≤1.3mm <sup>2</sup>
		I <sub>max</sub> ≤0.1A		

Remark: if the model number is without "S", the model is without remote control contact function