

# FV50C/2 -\*\*\*(S)

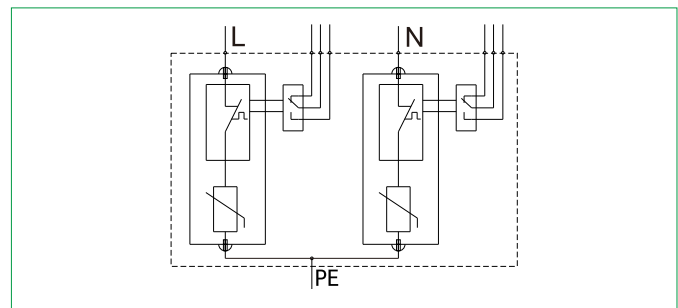

- ◆ Consisting of a base part and MOV pluggable modules.
- ◆ For using in the lightning protection zones concept at boundary 1-2.
- ◆ The core parts are metal oxide varistor components with high discharge capacity.
- ◆ Low residual voltage and quick response.
- ◆ Reliable control thanks to Thermo Dynamic Control disconnecter.
- ◆ With remote signaling contact for control device.
- ◆ Fault indication via red mark in the inspection window.
- ◆ Protection mode: L-PE, N-PE.

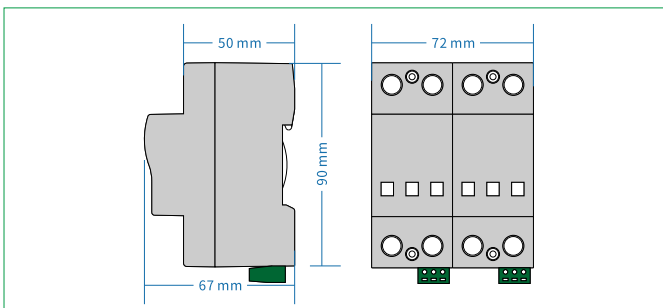

Model No.	FV50C/2-150(S)	FV50C/2-275(S)	FV50C/2-320(S)	FV50C/2-385(S)	FV50C/2-440(S)
Test class IEC/EN/VDE	Class II/C/ <u>TT</u>				
Type of Network	TT, TN				
Protection Mode	L - PE, N - PE				
Nominal voltage 50(60)Hz U <sub>N</sub>	110/220~	220/380V~	220/380V~	220/380V~	220/380V~
Rated Voltage (Max. Cont. Operating Voltage) U <sub>c</sub>	150V~	275V~	320V~	385V~	440V~
Max. discharge current (8/20μs) I <sub>max</sub>	100kA				
Nominal discharge current (8/20μs) I <sub>n</sub>	50kA				
Voltage protective level U <sub>p</sub>	≤1.2kV	≤1.8kV	≤2.2kV	≤2.5kV	≤2.8kV
Response time t <sub>a</sub>	≤25ns				
Recommended back-up fuse	125A				
Isolation resistance	>10 <sup>2</sup> MΩ				
I/O Connections	Multi core wire: 6mm <sup>2</sup> ~35mm <sup>2</sup>				
Mounting	35mm Symmetrical rail (EN50022/DIN46277-3)				
Operation temperature range / humidity / altitude	-40°C~+80°C / 30%~90% / 3000m				
Degree of protection	IP20				
Housing material	UL94 V-0				
Disconnection indicator	Mechanical indicator (Red: replace)				
Remote control contact	Optional				

Port definition of remote control contact	Range of signal access		Recommended wire specification	
	AC	U <sub>max</sub> ≤250V	Single core wire	Max ≤1.5mm <sup>2</sup>
		I <sub>max</sub> ≤0.5A		
	DC	U <sub>max</sub> ≤60V	Multi core wire	Max ≤1.3mm <sup>2</sup>
		I <sub>max</sub> ≤0.1A		

Remark: if the model number is without "S", the model is without remote control contact function

Low-voltage Power System