

FV40C/1 -*** (S)

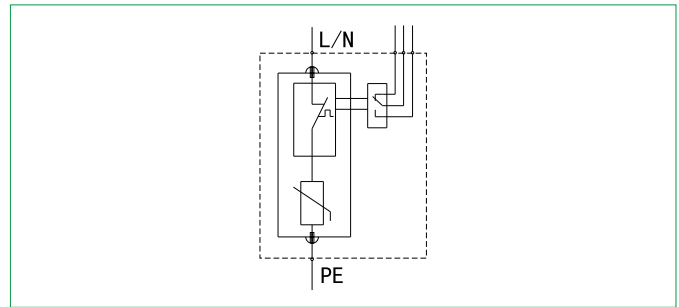

- ◆ Consisting of a base part and MOV pluggable protection modules.
- ◆ For using in the lightning protection zones concept at boundary 1-2.
- ◆ The core parts are metal oxide varistor components with high discharge capacity.
- ◆ Low residual voltage and quick response.
- ◆ Reliable control thanks to Thermo Dynamic Control disconnecter.
- ◆ With remote signaling contact for control device.
- ◆ Fault indication via red mark in the inspection window.
- ◆ Protection mode: L/N-PE.

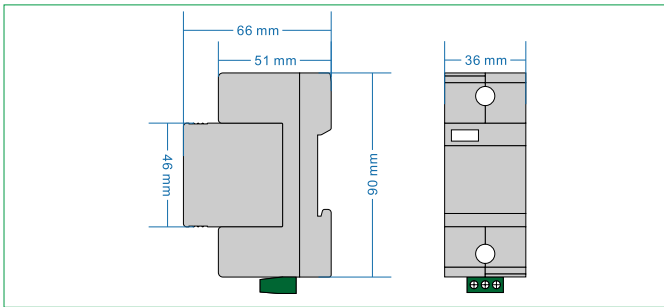

Model No.	FV40C/1-150 (S)	FV40C/1-275 (S)	FV40C/1-320 (S)	FV40C/1-385 (S)	FV40C/1-440 (S)
Test class IEC/EN/VDE	Class II/C/ <u>TT</u>				
Type of Network	TT, TN, IT				
Protection Mode	L / N - PE				
Nominal voltage 50(60)Hz U _n	110V~	220V~	220V~	220V~	220V~
Rated Voltage (Max. Cont. Operating Voltage) U _c	150V~	275V~	320V~	385V~	440V~
Max. discharge current (8/20μs) I _{max}	80kA				
Nominal discharge current (8/20μs) I _n	40kA				
Voltage protective level U _p	≤1.0kV	≤1.7kV	≤2.0kV	≤2.5kV	≤2.7kV
Response time t _a	≤25ns				
Recommended back-up fuse	125A				
Isolation resistance	>10 ² MΩ				
I/O Connections	Multi core wire: 6mm ² ~35mm ²				
Mounting	35mm Symmetrical rail (EN50022/DIN46277-3)				
Operation temperature range / humidity / altitude	-40°C~+80°C / 30%~90% / 3000m				
Degree of protection	IP20				
Housing material	UL94 V-0				
Disconnection indicator	Mechanical indicator (Green: OK, Red: replace)				
Remote control contact	Optional				

Port definition of remote control contact	Range of signal access		Recommended wire specification	
	AC	U _{max} ≤250V	Single core wire	Max ≤1.5mm ²
		I _{max} ≤0.5A		
	DC	U _{max} ≤60V	Multi core wire	Max ≤1.3mm ²
		I _{max} ≤0.1A		

Remark: if the model number is without "S", the model is without remote control contact function