

# FV20C/3+NPE -\*\*\*(S)

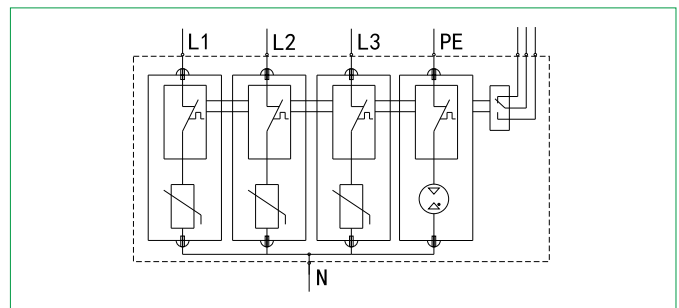

- ◆ Consisting of a base part and MOV + GDT pluggable protection modules.
- ◆ For using in the lightning protection zones concept at boundary 1-2.
- ◆ The core parts are metal oxide varistor components with high discharge capacity.
- ◆ Low residual voltage and quick response.
- ◆ Reliable control thanks to Thermo Dynamic Control disconnecter.
- ◆ With remote signaling contact for control device.
- ◆ Fault indication via red mark in the inspection window.
- ◆ Protection mode: L1,L2,L3-N,N-PE.

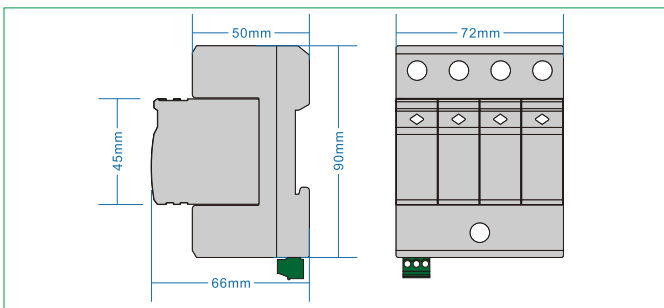

Model No.	FV20C/3+NPE-150(S)	FV20C/3+NPE-275(S)	FV20C/3+NPE-320(S)	FV20C/3+NPE-385(S)	FV20C/3+NPE-440(S)	
Test class IEC/EN/VDE	Class II/C/ <u>TT</u>					
Type of Network	TT					
Protection Mode	L1, L2, L3 - N, N - PE					
Nominal voltage 50(60)Hz U <sub>N</sub>	110/220V~	220/380V~	220/380V~	220/380V~	220/380V~	
Rated Voltage (Max. Cont. Operating Voltage) U <sub>c</sub>	150V~	275V~	320V~	385V~	440V~	
Max. discharge current (8/20μs) I <sub>max</sub>	40kA					
Nominal discharge current (8/20μs) I <sub>n</sub>	20kA					
Voltage protective level U <sub>p</sub>	L-N	≤0.7kV	≤1.2kV	≤1.5kV	≤1.8kV	≤2.0kV
	N-PE	≤1.5kV	≤1.5kV	≤1.5kV	≤1.5kV	≤1.5kV
Response time t <sub>A</sub>	L-N: ≤25ns, N-PE: ≤100ns					
Recommended back-up fuse	125A					
Isolation resistance	>10 <sup>2</sup> MΩ					
I/O Connections	Multi core wire: 4mm <sup>2</sup> ~25mm <sup>2</sup>					
Mounting	35mm Symmetrical rail (EN50022/DIN46277-3)					
Operation temperature range / humidity / altitude	-40°C~+80°C / 30%~90% / 3000m					
Degree of protection	IP20					
Housing material	UL94 V-0					
Disconnection indicator	Mechanical indicator (Green: OK, Red: replace)					
Remote control contact	Optional					

Port definition of remote control contact	Range of signal access		Recommended wire specification	
	AC	U <sub>max</sub> ≤250V	Single core wire	Max ≤1.5mm <sup>2</sup>
		I <sub>max</sub> ≤0.5A		
	DC	U <sub>max</sub> ≤60V	Multi core wire	Max ≤1.3mm <sup>2</sup>
		I <sub>max</sub> ≤0.1A		

Remark: if the model number is without "S", the model is without remote control contact function

Low-voltage Power System