

FV05D/3+NPE -*** (S)

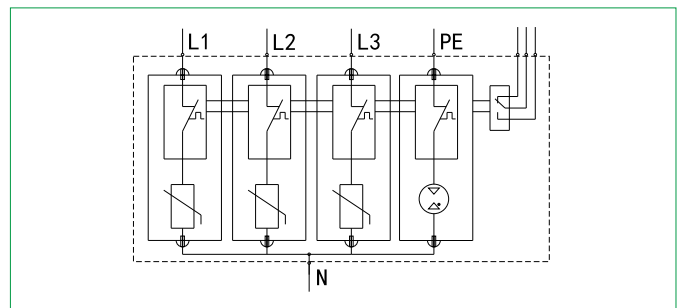

- ◆ Consisting of a base part and MOV + GDT pluggable protection modules.
- ◆ For using in the lightning protection zones concept at boundary 1-2.
- ◆ The core parts are metal oxide varistor components with high discharge capacity.
- ◆ Low residual voltage and quick response.
- ◆ Reliable control thanks to Thermo Dynamic Control disconnecter.
- ◆ With remote signaling contact for control device.
- ◆ Fault indication via red mark in the inspection window.
- ◆ Protection mode: L1, L2, L3-N, N-PE.

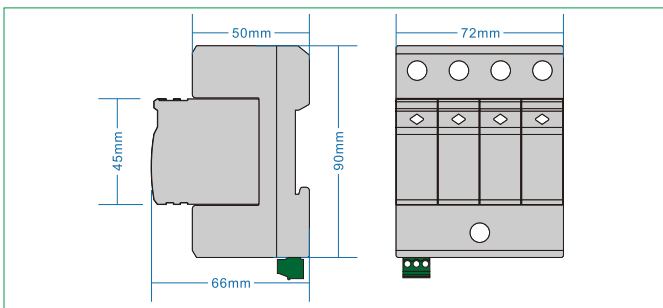

Model No.	FV05D/3+NPE-150(S)	FV05D/3+NPE-275(S)	FV05D/3+NPE-320(S)	FV05D/3+NPE-385(S)	FV05D/3+NPE-440(S)	
Test class IEC/EN/VDE	Class II+III/C+D/ $\overline{T2}$ $\overline{T3}$					
Type of Network	TT					
Protection Mode	L1, L2, L3 - N, N - PE					
Nominal voltage 50(60)Hz U_N	110/220V~	220/380V~	220/380V~	220/380V~	220/380V~	
Rated Voltage (Max. Cont. Operating Voltage) U_c	150V~	275V~	320V~	385V~	440V~	
Max. discharge current (8/20 μ s) I_{max}	10kA					
Nominal discharge current (8/20 μ s) I_n	5kA					
Voltage protective level U_p	L-N	$\leq 0.7kV$	$\leq 1.2kV$	$\leq 1.5kV$	$\leq 1.8kV$	$\leq 2.0kV$
	N-PE	$\leq 1.5kV$	$\leq 1.5kV$	$\leq 1.5kV$	$\leq 1.5kV$	$\leq 1.5kV$
Open circuit voltage U_{oc}	10kV					
Response time t_a	L-N: $\leq 25ns$, N-PE: $\leq 100ns$					
Recommended back-up fuse	16A					
Isolation resistance	$> 10^2 M\Omega$					
I/O Connections	Multi core wire: 4mm ² ~25mm ²					
Mounting	35mm Symmetrical rail (EN50022/DIN46277-3)					
Operation temperature range / humidity / altitude	-40°C~+80°C / 30%~90% / 3000m					
Degree of protection	IP20					
Housing material	UL94 V-0					
Disconnection indicator	Mechanical indicator (Green: OK, Red: replace)					
Remote control contact	Optional					

Port definition of remote control contact	Range of signal access		Recommended wire specification	
	AC	$U_{max} \leq 250V$	Single core wire	Max $\leq 1.5mm^2$
		$I_{max} \leq 0.5A$		
	DC	$U_{max} \leq 60V$	Multi core wire	Max $\leq 1.3mm^2$
		$I_{max} \leq 0.1A$		

Remark: if the model number is without "S", the model is without remote control contact function